

CONVERSION TRACK SYSTEMS



FORMERLY
CAMOPLAST
SOLIDEAL





ON ANY GROUND ON ANY EQUIPMENT

The Camso conversion track system increases your machine's mobility and flotation for better access to fields with soft ground conditions. Its large footprint reduces ground compaction, minimizes field damage, and increases stability, maximizing the overall efficiency and quality of your work. Flexible and adaptable like no other, it can be used on different machine models and applications.

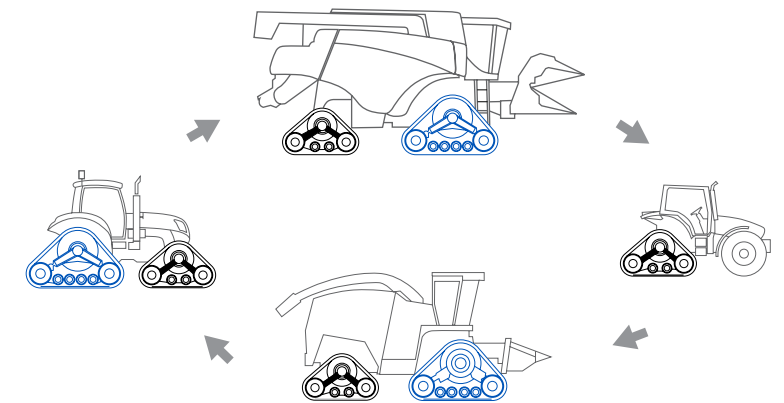

THE CAMSO CONVERSION TRACK SYSTEM IS ENGINEERED FOR THE TOUGHEST CONDITIONS AND REDUCES GROUND PRESSURE BY OVER 65%.

COMBINE APPLICATIONS



CONVERSION TRACK SYSTEM FOR COMBINES

NEW CAMSO CTS HIGH SPEED

Faster roading speeds, more performance

The industry's first 100% bolt-on track system for combines with an integrated final drive system to achieve similar roading speeds to wheeled combines.



PERFORMANCE SPEED



FLOTATION



RIDE QUALITY



CAMSO CTS SUSPENDED

Field ready when you're ready

Designed to improve ride quality and achieve maximum ground contact.

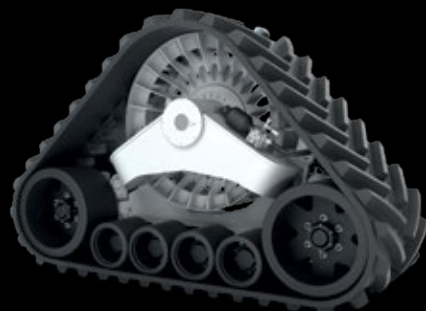

PERFORMANCE SPEED



FLOTATION



RIDE QUALITY



CAMSO CTS STANDARD

More access to fields for maximum yields

Designed to increase field access and stability in soft ground conditions.



PERFORMANCE SPEED



FLOTATION



RIDE QUALITY

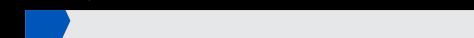

NEW

CTS HIGH SPEED

Faster roading speeds, more performance

Field ready when you're ready. The new CTS is the industry's first 100% bolt-on track system for combines with an integrated final drive system to achieve similar roading speeds to wheeled combines. Get into your field faster than ever before.

36Q17MK JD 264

Track width	36"
Track system height	64.1"
Track system length	114.2"
Flat plate area per pair (in ²)	5,936

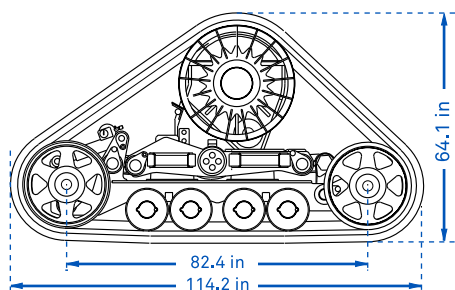

NEW Integrated final drive

Allows the combine to achieve speeds of up to 23 mph

- Matches the right gear ratio to achieve speeds similar to wheeled combines

Hydraulic tensioning system

Maximizes tractive performance and keeps sprocket and lug at optimum contact to extend track life

- Hydraulic tensioning system with nitrogen-charged accumulator

Suspension

Improves ground contact on uneven terrain, which helps transfer power to the ground

- Improves machine stability and header placement
- Patented double oscillating bogie wheels

Main frame

Resulting in smoother ride and less wear on equipment and operator

- Suspended upper and lower frame design with polyurethane isolation

Wheels

Simplifies maintenance operations

- Heavy-duty wheel hubs with oil bath lubrication
- No greasing or repacking of bearings

Track

Larger footprint that offers over 70% reduction in ground pressure

- Increases mobility on soft ground conditions

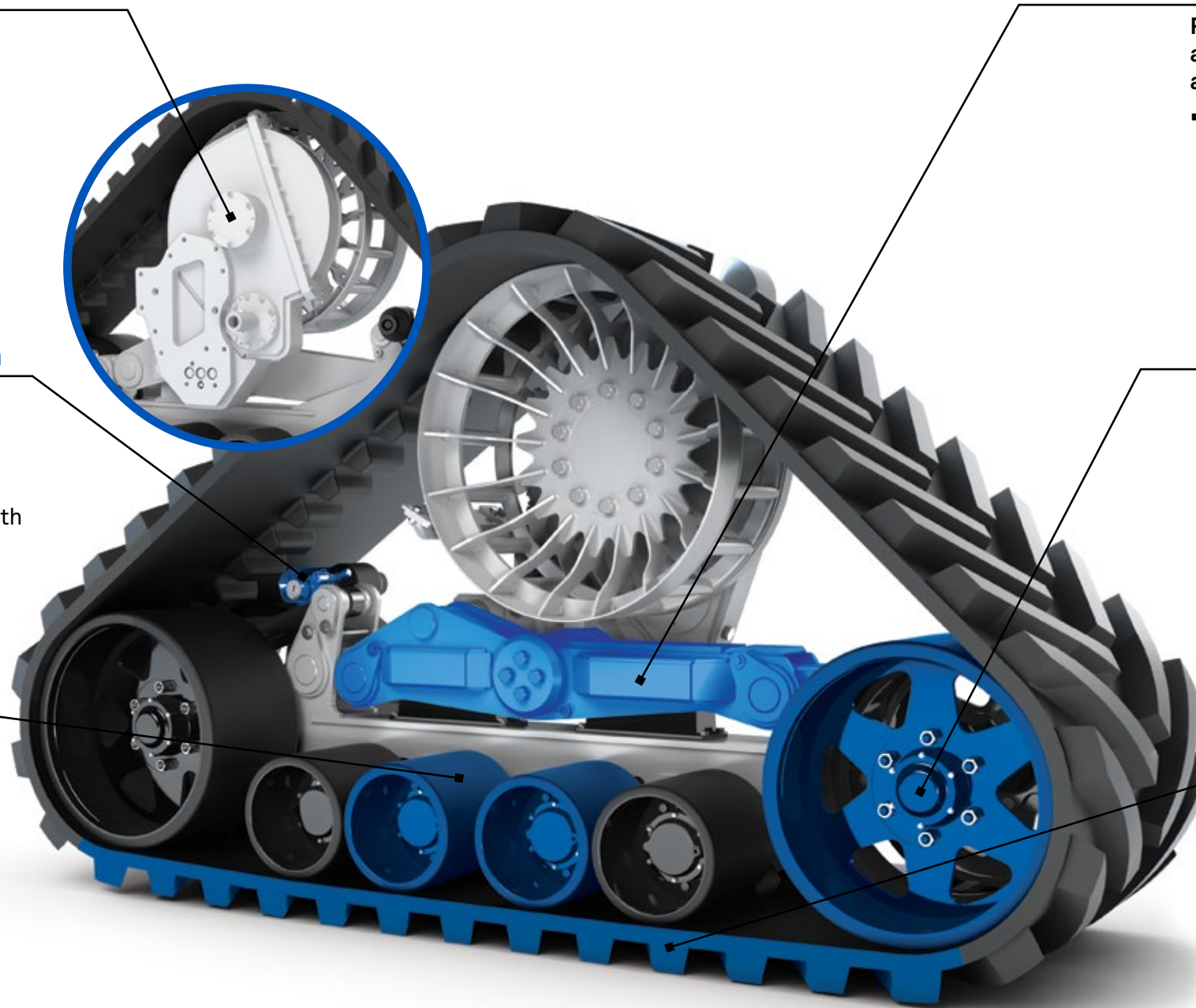

CTS SUSPENDED

Field ready when you're ready

Designed to increase field access, stability and ride comfort. The best choice for combines facing the toughest conditions.

36Q23MA

Track width	36"
Track system height	65"
Track system length	104"
Flat plate area per pair (in ²)	5,285

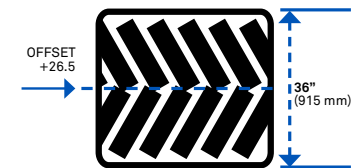
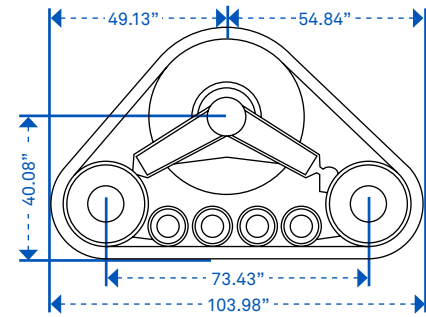

36" wide track

Main frame

Resulting in smoother ride and less wear on equipment and operators

- Suspended upper and lower frame design with rubber isolation

Only applicable for CTS High Speed and CTS Suspended

Suspension

Improves ground contact on uneven terrain, which helps transfer power to the ground

- Improves machine stability and header placement
- Patented double oscillating bogie wheels

Only applicable for CTS High Speed and CTS Suspended



OPTIONAL SPEED MULTIPLIER

Optional on 36Q track systems

- 30% faster roading speed out of your CTS
- Heavy duty gear box design
- 100% bolt-on feature that mounts between track system and final drive

Hydraulic tensioning system

Maximizes tractive performance and keeps sprocket and lug at optimum contact to extend track life

- Hydraulic tensioning system with nitrogen-charged accumulator

Wheels

Simplifies maintenance operations

- Heavy-duty wheels hubs with oil bath lubrication
- No greasing or repacking of bearings

Track

Large footprint that offers over 65% reduction in ground pressure

- Increases mobility on soft ground conditions

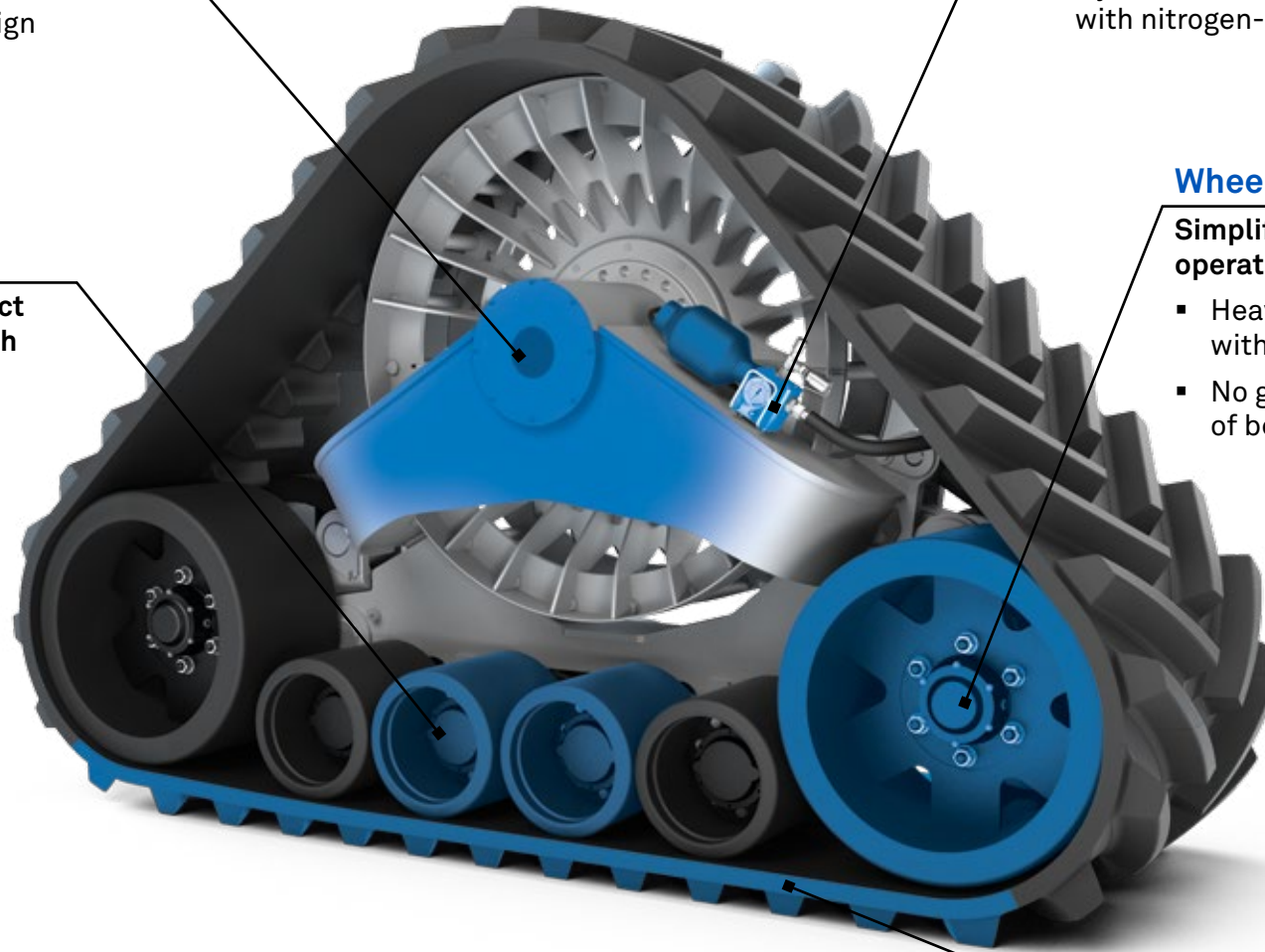

CTS STANDARD

More access to fields for maximum yields

Designed to increase field access and stability in soft ground conditions.

36T23A

Track width	36"
Track system height	64.6"
Track system length	104.3"
Flat plate area per pair (in ²)	5,309

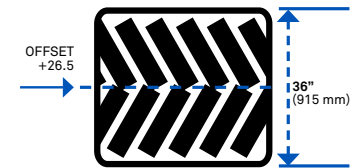
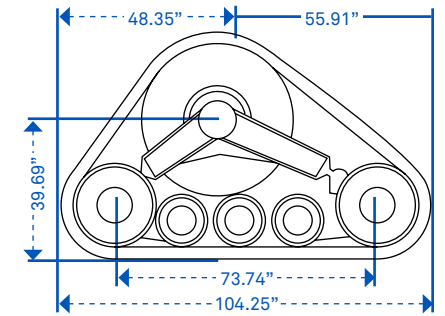

36" wide track

TRACTOR APPLICATIONS



CONVERSION TRACK SYSTEM FOR TRACTOR

CAMSO CTS TRACTOR

Reduces compaction zones and increases traction

Engineered to easily convert tractors to tracks with minimum maintenance. It's the simplest MFWD conversion track system in the market. With excellent traction and flotation in wet or soft ground conditions, it's a perfect choice for tillage and rice fields.

PERFORMANCE
SPEED



FLOTATION



RIDE QUALITY



REAR

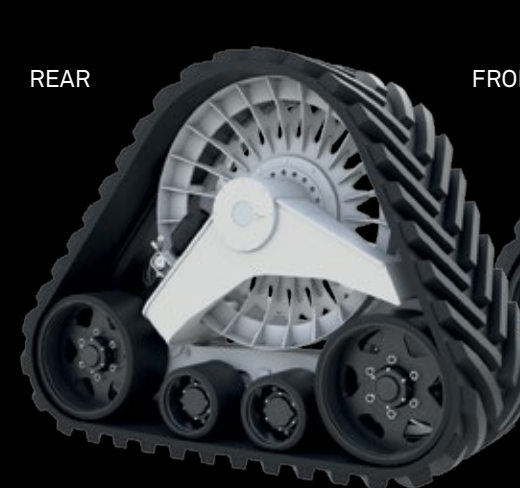

FRONT



CTS TRACTOR

Reduce your compaction zones and increase traction

Engineered to easily convert tractors to tracks. With excellent traction and flotation in wet or soft ground conditions, it's a perfect choice for tillage and rice fields.

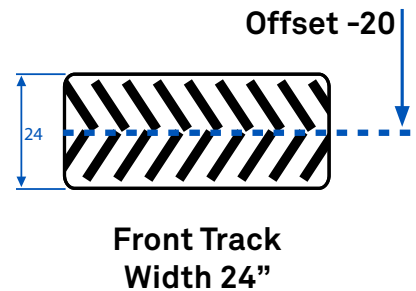
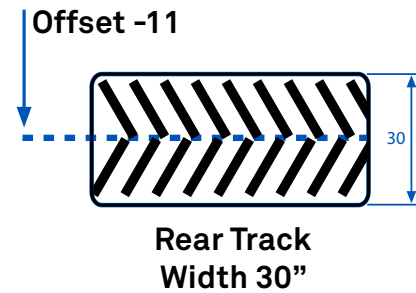

Sprocket

To get the most power to the ground

- Positive drive sprocket designed to engage up to 8 drive lugs

Main frames

Simplifies maintenance operations

- Oil bath drive hubs

Suspension

Improves ground contact on uneven terrain to help transfer power to the ground

- Patented double oscillating bogie wheels

Hydraulic tensioning system

Maximizes tractive performance hydraulic tensioning system with nitrogen-charged accumulator

- Maintains track tension for each system independently

Track

Improves traction

- Designed with a large track footprint to reduce ground pressure and high traction tread pattern

Wheels

Simplifies maintenance operations

- Heavy duty wheel hubs with oil bath lubrication
- No greasing or repacking of bearings

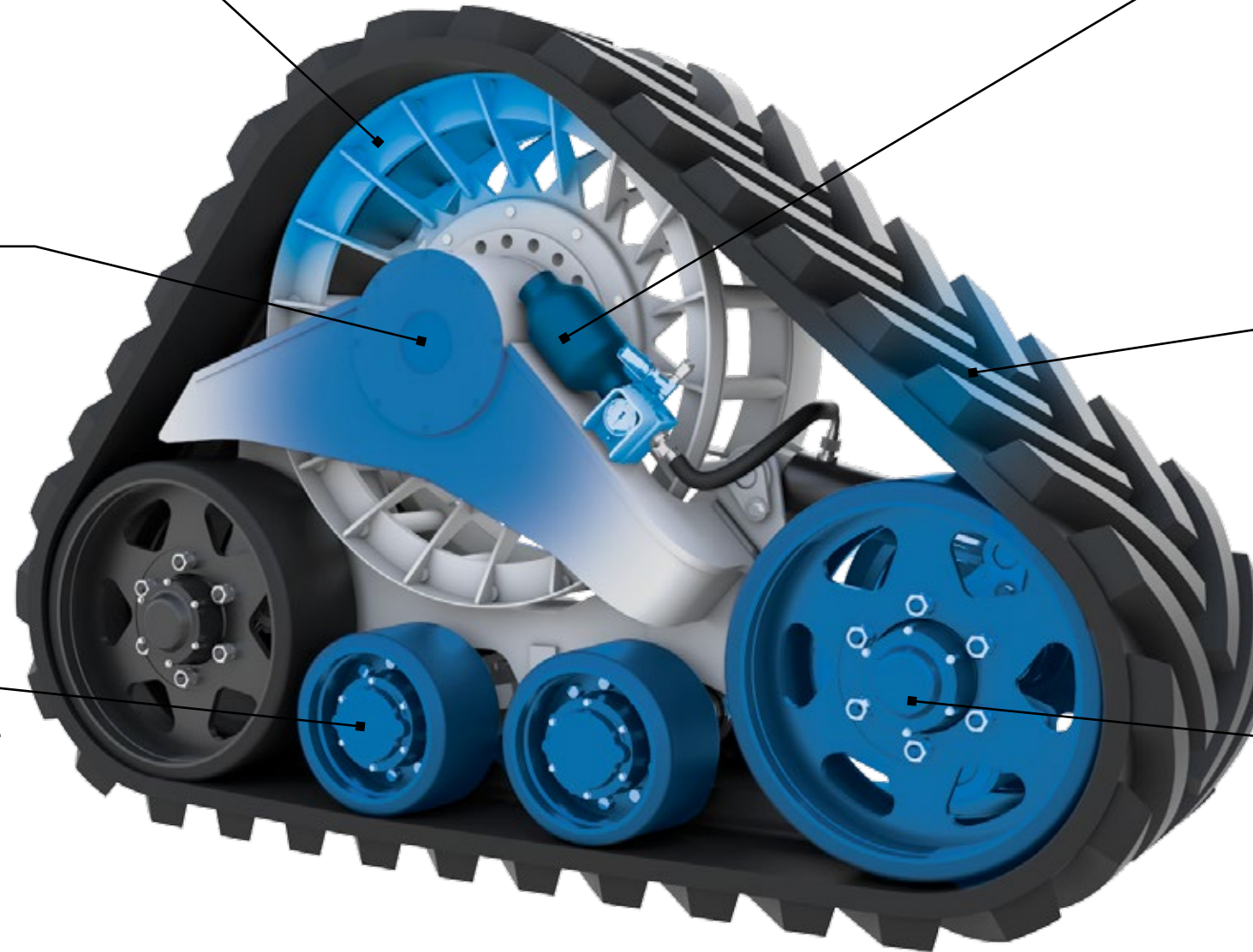

CAMSO CTS TRACTOR

TRACK SYSTEM FRONT

24D18C

Track width	24"
Track system height	53.8"
Track system length	82.1"
Flat plate area per pair (in ²)	2,568

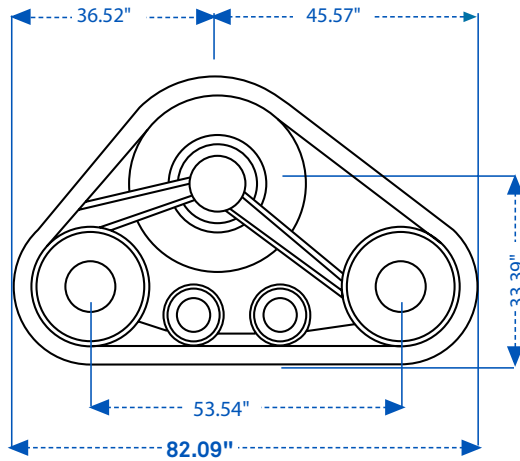

TRACK SYSTEM REAR

30D23MC

Track width	30"
Track system height	64.6"
Track system length	85.2"
Flat plate area per pair (in ²)	3,402

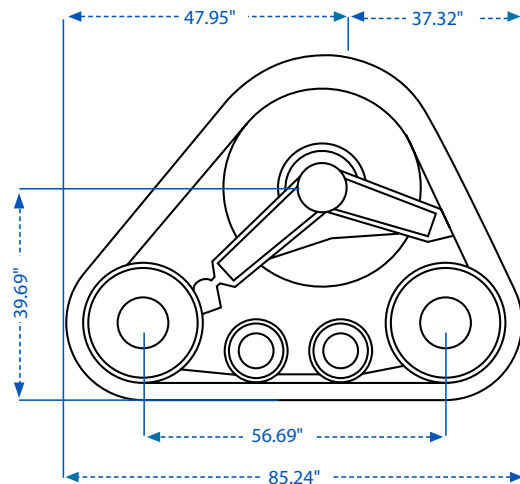

Camso provides comprehensive warranty coverage for a period of 12 months from date of purchase, for Conversion Track System (CTS) against defects in materials and workmanship. Some conditions apply. Refer to the warranty certificate for details. For more info, visit camso.co/agriculture

THINK NEXT GENERATION

We constantly create enhanced tracks and track systems that provide the mobility solutions to help you get the job done.
We think next generation.

1706_AG_CTSBrochureNA_EN | Printed in Canada

We are dedicated to our clients and customers. For the AG customer service, contact us toll free at 1 844 CAMSOAG, or 1 317 671-7327, or by email at Ag.ProductSupport@camso.co

Connect with us for exclusive Road Free content



@camso.co



@camso_co



@camso_co



camso.co



FORMERLY
CAMOPLAST
SOLIDEAL